

Accessories
Mounting Kit
BTS-DSU35-Z03

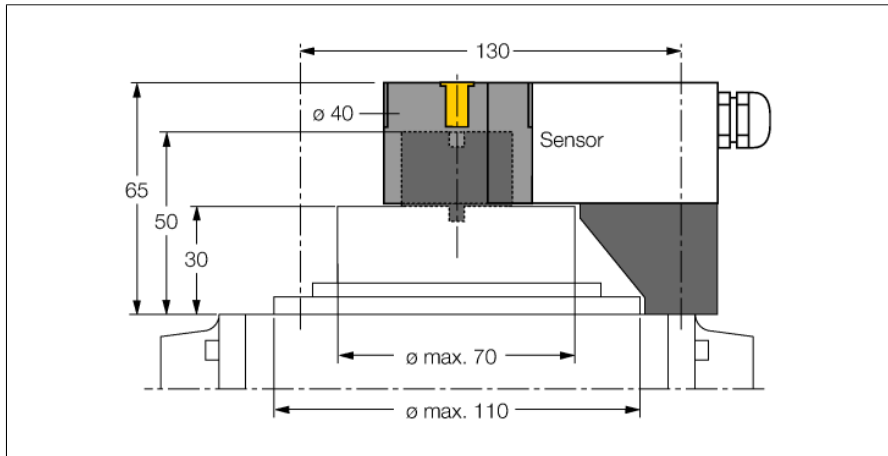

Mounting kit for larger rotary actuators:
Ø spacer plate and snap ring: max. 110 mm
Hole pattern on flange surface: 30 x 130 mm

Connection shaft (shaft extension) height:
30 mm/Ø: max. 70 mm

Included in delivery:

1 spacer plate Ø 30 mm (POM)

1 spacer ring Ø 20 mm (PP-GF30)

Mounting the spacer plate:

2 cylinder screws M5 x 12 [DIN 912-A2]

2 cylinder screws M5 x 45 [DIN 912-A2]

2 lock washers A5 [DIN 137-A2]

Mounting the puck with spacer ring:

1 countersunk screw M6 x 45 [DIN 7991-A2]

The spacer ring has a 4 x 4 mm cross-shaped notch allowing the actuator to be mounted offset by 90°, suited for cross-wise-mounted drives.

Type designation
Ident no.

BTS-DSU35-Z03
6900231

Design
Housing material

Accessories for dual sensor, Ni4-DSU35...
Plastic

General description

Dual sensors are especially designed for position detection in rotary actuators. They combine the reliability of non-contact inductive sensors with the flexibility of a modular housing system. A broad range of practice-oriented accessories ensure optimal adaption to your system.

