

BL67 electronic module

8 Configurable Digital Channels, PNP, Channel Diagnostics, 0.5 A

BL67-8XSG-PD

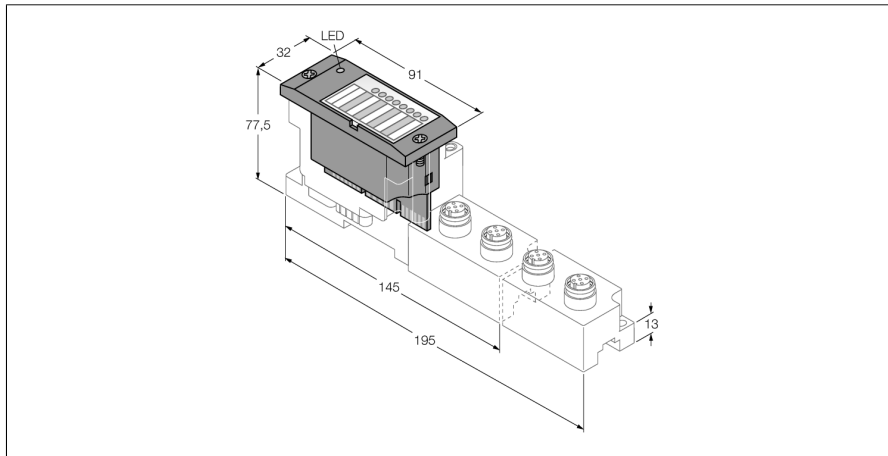

- Independent of the type of fieldbus and connection technology used
- Protection class IP67
- LEDs indicate status and diagnostic
- Electronics galvanically separated from the field level via optocouplers
- 8 configurable digital channels
- 24 VDC, PNP
- Max. 0.5 A
- Channel diagnostics
- Adjustable filter times
- Invertible inputs

Type designation	BL67-8XSG-PD
Ident no.	6827208
Number of channels	8
Supply voltage	24 VDC
Nominal voltage V_N	24 VDC
Nominal current from field supply	≤ 100 mA
Nominal current from module bus	≤ 30 mA
Max. sensor supply I_{sens}	100 mA For 2 channels (\Rightarrow e.g. per M12 slot), electronically limited current supply
max. load current I_L	10 A via gateway or power feed
Power dissipation, typical	≤ 1.5 W
Input type	pnp
Type of input diagnostics	channel diagnostics
Low level signal voltage	< 4.5 V
High level signal voltage	7...30 V
Low level signal current	< 1.5 mA
High level signal current	2.1...3.7 mA
Input delay	0.25; 2.5 ms
Electrical isolation	electronics for the field level
Output connectivity	M8, M12, M23
Output type	PNP
Output voltage	24 VDC
Output current per channel	0.5 A
Output delay	3 ms
Load type	resistive, inductive, lamp load
Load resistance, resistive	$> 48 \Omega$
Load resistance, inductive	< 1.2 H
Lamp load	< 3 W
Switching frequency, resistive	< 200 Hz
Switching frequency, inductive	< 2 Hz
Switching frequency, lamp load	< 20 Hz
Simultaneity factor	1
Electrical isolation	electronics for the field level
Number of diagnostic bits	12
Number of parameter bytes	8

Functional principle

BL67 electronic modules are plugged into the purely passive base modules which are needed for connection of field devices. The separation of connection level and electronics simplifies maintenance considerably. Flexibility is enhanced because the user can choose between base modules with different connection technologies.

The electronic modules are completely independent of the higher level fieldbus through the use of gateways.

Note

The inputs and outputs of the digital combi-module are supplied via a common GND. Therefore, we recommend **not** to use this module for safety or emergency stop applications.

Otherwise, it must be ensured that V_I and V_O at the gateway or power feeding module are all-pole disabled.

BL67 electronic module

8 Configurable Digital Channels, PNP, Channel Diagnostics, 0.5 A

BL67-8XSG-PD

Dimensions (W x L x H)	32 x 91 x 59mm
Approvals	CE, cULus
Ambient temperature	-40...+70 °C
Temperature derating	
< 0 °C Ambient temperature	Support for version VN 01-03 and higher, no limitation
> 55 °C Steady ambient air	Simultaneity factor 0.5
Storage temperature	-40...+85 °C
Relative humidity	5 to 95 % (internal), Level RH-2, no condensation (at 45 °C storage)
Vibration test	Acc. to EN 61131
- up to 5 g (at 10 to 150 Hz)	for mounting on DIN rail no drilling according to EN 60715, with end bracket
- up to 20 g (at 10 up to 150 Hz)	for mounting on base plate or machinery Therefore every second module has to be mounted with two screws each.
Shock test	Acc. to IEC 60068-2-27
Drop and topple	acc. to IEC 68-2-31 and free fall to IEC 68-2-32
Electromagnetic compatibility	Acc. to EN 61131-2
Protection class	IP67
Tightening torque fixing screw	0.9...1.2 Nm



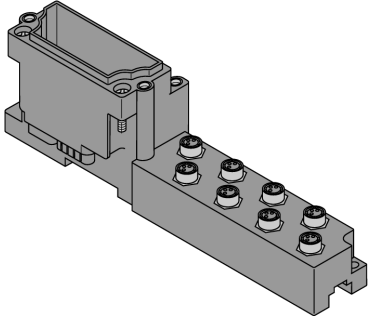
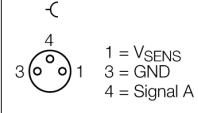
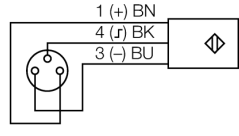
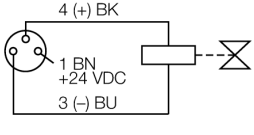
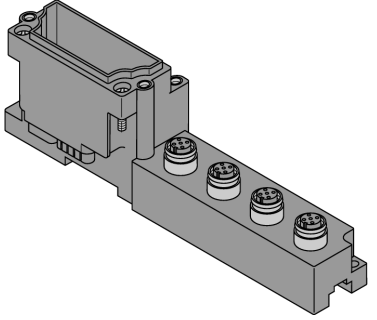
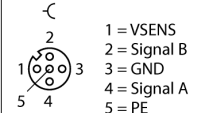
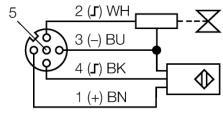
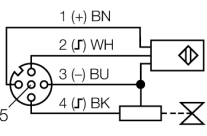
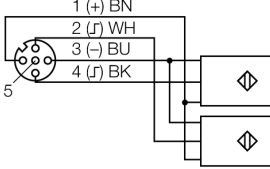
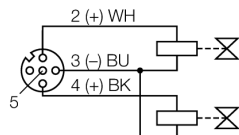

BL67 electronic module
8 Configurable Digital Channels, PNP, Channel Diagnostics, 0.5 A
BL67-8XSG-PD

Compatible base modules

Dimension drawing	Type	Pin configuration
	<p>BL67-B-8M8 6827188 8 x M8, 3-pole, female</p> <p>Comments Matching connection cable (for example): PKG3M-2-PSW3M/TXL Ident-No. 6625668</p>	<p>Pin Assignment</p>  <p>Wiring Diagram</p>  <p>Wiring diagram</p> 
	<p>BL67-B-4M12 6827187 4 x M12, 5-pole, female</p> <p>Comments Matching connection cable (for example): RKC4.4T-2-RSC4.4T/TXL Ident-No. 6625608</p> <p>BL67-B-4M12-P 6827195 4 x M12, 5-pole, female, paired</p> <p>Comments Matching connection cable (for example): RKC4.4T-2-RSC4.4T/TXL Ident-No. 6625608</p>	<p>Pin Assignment</p>  <p>Wiring Diagram</p>  <p>Wiring diagram</p>  <p>Wiring diagram</p>  <p>Wiring diagram</p> 

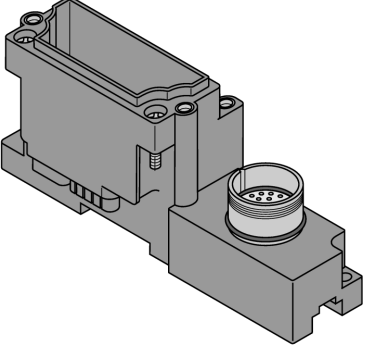
BL67 electronic module
8 Configurable Digital Channels, PNP, Channel Diagnostics, 0.5 A
BL67-8XSG-PD

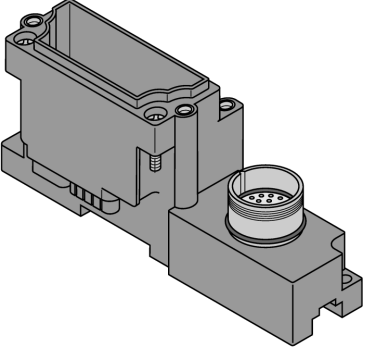
Compatible base modules

Dimension drawing	Type	Pin configuration												
	<p>BL67-B-1M23-VI 6827290 1 x M23, 12-pole, female</p> <p>Comments field-wireable connector (for example): FW-M23ST12Q-G-LT-ME-XX-10 Ident-No. 6604070</p> <p>Note Channel related diagnostics is not possible with this base module. 4A current limited power supply to the sensor via gateway or power feeding module.</p>	<p>Pin Assignment</p>  <table border="0"> <tr> <td>1 = Signal 0</td> <td>7 = Signal 6</td> </tr> <tr> <td>2 = Signal 1</td> <td>8 = Signal 7</td> </tr> <tr> <td>3 = Signal 2</td> <td>9 = V_{SENS}</td> </tr> <tr> <td>4 = Signal 3</td> <td>10 = V_{SENS}</td> </tr> <tr> <td>5 = Signal 4</td> <td>11 = V_{SENS}</td> </tr> <tr> <td>6 = Signal 5</td> <td>12 = GND</td> </tr> </table>	1 = Signal 0	7 = Signal 6	2 = Signal 1	8 = Signal 7	3 = Signal 2	9 = V _{SENS}	4 = Signal 3	10 = V _{SENS}	5 = Signal 4	11 = V _{SENS}	6 = Signal 5	12 = GND
1 = Signal 0	7 = Signal 6													
2 = Signal 1	8 = Signal 7													
3 = Signal 2	9 = V _{SENS}													
4 = Signal 3	10 = V _{SENS}													
5 = Signal 4	11 = V _{SENS}													
6 = Signal 5	12 = GND													
	<p>BL67-B-1M23 6827213 1 x M23, 12-pole, female</p> <p>Comments field-wireable connector (for example): FW-M23ST12Q-G-LT-ME-XX-10 Ident-No. 6604070</p> <p>Note Channel related diagnostics is restricted with this base module. The sensor supply is electronically current limited to 3 * 100mA (pin 9, 10, 11).</p>	<p>Pin Assignment</p>  <table border="0"> <tr> <td>1 = Signal 0</td> <td>7 = Signal 6</td> </tr> <tr> <td>2 = Signal 1</td> <td>8 = Signal 7</td> </tr> <tr> <td>3 = Signal 2</td> <td>9 = V_{SENS}</td> </tr> <tr> <td>4 = Signal 3</td> <td>10 = V_{SENS}</td> </tr> <tr> <td>5 = Signal 4</td> <td>11 = V_{SENS}</td> </tr> <tr> <td>6 = Signal 5</td> <td>12 = GND</td> </tr> </table>	1 = Signal 0	7 = Signal 6	2 = Signal 1	8 = Signal 7	3 = Signal 2	9 = V _{SENS}	4 = Signal 3	10 = V _{SENS}	5 = Signal 4	11 = V _{SENS}	6 = Signal 5	12 = GND
1 = Signal 0	7 = Signal 6													
2 = Signal 1	8 = Signal 7													
3 = Signal 2	9 = V _{SENS}													
4 = Signal 3	10 = V _{SENS}													
5 = Signal 4	11 = V _{SENS}													
6 = Signal 5	12 = GND													

BL67 electronic module
8 Configurable Digital Channels, PNP, Channel Diagnostics, 0.5 A
BL67-8XSG-PD

LED display

LED	Color	Status	Meaning
D		OFF	No error message or diagnostics active.
	RED	ON	Failure of module bus communication. Check if more than 2 adjacent electronic modules are pulled. Relevant modules are located between gateway and this module.
	RED	FLASHING (0.5 Hz)	Upcoming module diagnostics
XSG channels 0...7		OFF	Status channel x = 0 (OFF), no active diagnostics
	GREEN	ON	Status channel x = 1 (ON)
	RED	ON	Short-circuit at output
	RED	FLASHING (2 Hz)	Short-circuit sensor supply

BL67 electronic module

8 Configurable Digital Channels, PNP, Channel Diagnostics, 0.5 A

BL67-8XSG-PD

Data mapping

DATA	BYTE	Bit 7	Bit 6	Bit 5	Bit 4	Bit 3	Bit 2	Bit 1	Bit 0
Input	n	XSG 7	XSG 6	XSG 5	XSG 4	XSG 3	XSG 2	XSG 1	XSG 0
Output	m	XSG 7	XSG 6	XSG 5	XSG 4	XSG 3	XSG 2	XSG 1	XSG 0

Note:

Simultaneous feedback of status at the input and the digital output.

n = Offset of input data; depending on extension of station and the corresponding fieldbus.

m = Offset of output data; depending on extension of station and the corresponding fieldbus.

With PROFIBUS, PROFINET and CANopen, the I/O data of this module is localized within the process data of the whole station via the hardware configuration tool of the fieldbus master.

With DeviceNet™, EtherNet/IP™ and Modbus TCP a detailed mapping table can be created with the TURCK configuration tool I/O-ASSISTANT.

Pin assignment at corresponding base module:

DATA	BYTE	Bit 7	Bit 6	Bit 5	Bit 4	Bit 3	Bit 2	Bit 1	Bit 0
BL67-B-8M8									
Input	n	C7 P4	C6 P4	C5 P4	C4 P4	C3 P4	C2 P4	C1 P4	C0 P4
Output	m	C7 P4	C6 P4	C5 P4	C4 P4	C3 P4	C2 P4	C1 P4	C0 P4
BL67-B-4M12									
Input	n	C3 P2	C2 P2	C1 P2	C0 P2	C3 P4	C2 P4	C1 P4	C0 P4
Output	m	C3 P2	C2 P2	C1 P2	C0 P2	C3 P4	C2 P4	C1 P4	C0 P4
BL67-B-4M12-P									
Input	n	C3 P2	C3 P4	C2 P2	C2 P4	C1 P2	C1 P4	C0 P2	C0 P4
Output	m	C3 P2	C3 P4	C2 P2	C2 P4	C1 P2	C1 P4	C0 P2	C0 P4
BL67-B-2M12-8									
Input	n	C1 P4	C1 P3	C0 P4	C0 P3	C1 P2	C1 P1	C0 P2	C0 P1
Output	m	C1 P4	C1 P3	C0 P4	C0 P3	C1 P2	C1 P1	C0 P2	C0 P1
BL67-B-1M23(-VI)									
Input	n	C0 P8	C0 P7	C0 P6	C0 P5	C0 P4	C0 P3	C0 P2	C0 P1
Output	m	C0 P8	C0 P7	C0 P6	C0 P5	C0 P4	C0 P3	C0 P2	C0 P1

C... = slot no., P... = pin no.