

# BI1.5-EG08K-Y1

## Inductive Sensor

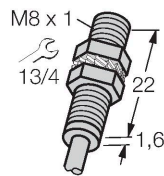

### Features

- Threaded barrel, M8 x 1
- Stainless steel, 1.4427 SO
- DC 2-wire, nom. 8.2 VDC
- Output acc. to DIN EN 60947-5-6 (NAMUR)
- Cable connection
- ATEX category II 1 G, Ex zone 0
- ATEX category II 1 D, Ex zone 20
- SIL2 (Low Demand Mode) acc. to IEC 61508, PL c acc. to ISO 13849-1 with HFT0
- SIL3 (All Demand Mode) acc. to IEC 61508, PL e acc. to ISO 13849-1 with redundant configuration HFT1

### Wiring diagram

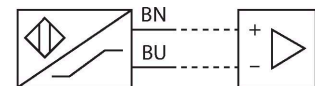

### Functional principle

Inductive sensors detect metal objects contactless and wear-free. For this, they use a high-frequency electromagnetic AC field that interacts with the target. Inductive sensors generate this field via an RLC circuit with a ferrite coil.

### Technical data

|   |  |
|---|--|
| Type  | BI1.5-EG08K-Y1   |
| ID  | 1003600  |
| <b>General data</b>   |  |
| Rated switching distance  | 1.5 mm   |
| Mounting conditions   | Flush  |
| Secured operating distance  | $\leq (0.81 \times S_n)$ mm  |
| Correction factors  | St37 = 1; Al = 0.3; stainless steel = 0.7; Ms = 0.4  |
| Repeat accuracy   | $\leq 2$ % of full scale   |
| Temperature drift   | $\leq \pm 10$ %  |
| Hysteresis  | 1...10 %   |
| <b>Electrical data</b>  |  |
| Output function   | 2-wire, NAMUR  |
| Switching frequency   | 5 kHz  |
| Voltage   | Nom. 8.2 VDC   |
| Non-actuated current consumption                                    | $\geq 2.1$ mA  |
| Actuated current consumption  | $\leq 1.2$ mA  |
| Approval acc. to  | KEMA 02 ATEX 1090X   |
| Internal capacitance (C <sub>i</sub> )/inductance (L <sub>i</sub> ) | 150 nF/150 $\mu$ H   |
| Device marking  | Ex II 1 G Ex ia IIC T6 Ga/II 1 D Ex ia III C T135 °C Da<br>(max. U <sub>i</sub> = 20 V, I <sub>i</sub> = 60 mA, P <sub>i</sub> = 130 mW) |
| <b>Mechanical data</b>  |  |
| Design  | Threaded barrel, M8 x 1  |
| Dimensions  | 23.6 mm  |
| Housing material  | Stainless steel, 1.4427 SO   |
| Active area material  | Plastic, PA12-GF20   |
| End cap   | Plastic, PP  |

## Technical data

|                                       |  |
|---------------------------------------|--|
| Max. tightening torque of housing nut | 5 Nm                                       |
| Electrical connection                 | Cable                                      |
| Cable quality                         | Ø 4 mm, Blue, Lif9YYW, PVC, 2 m            |
| Core cross-section                    | 2 x 0.25 mm <sup>2</sup>                   |
| <b>Environmental conditions</b>       |  |
| Ambient temperature                   | -25...+70 °C                               |
| Vibration resistance                  | 55 Hz (1 mm)                               |
| Shock resistance                      | 30 g (11 ms)                               |
| Protection class                      | IP67                                       |
| MTTF                                  | 6198 years acc. to SN 29500 (Ed. 99) 40 °C |

## Mounting instructions

### Mounting instructions/Description

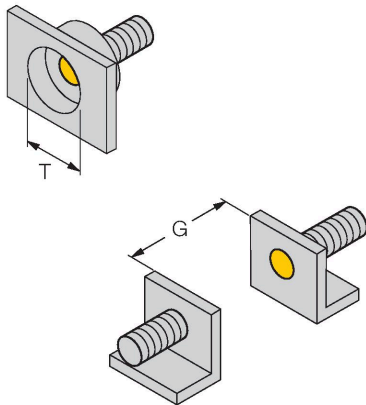

|                        |         |
|------------------------|---------|
| Distance D             | 2 x B   |
| Distance W             | 3 x Sn  |
| Distance T             | 3 x B   |
| Distance S             | 1.5 x B |
| Distance G             | 6 x Sn  |
| Diameter active area B | Ø 8 mm  |

## Accessories

**BST-08B** 6947210

Mounting clamp for threaded barrel sensors, with dead-stop; material: PA6

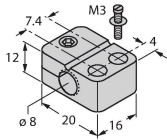

**QM-08** 6945100

Quick-mount bracket with dead-stop, chrome-plated brass, male thread M12 x 1. Note: The switching distance of proximity switches may be reduced through the use of quick-mount brackets.

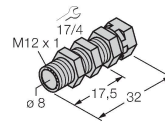

**MW-08** 6945008

Mounting bracket for threaded barrel sensors; material: Stainless steel A2 1.4301 (AISI 304)

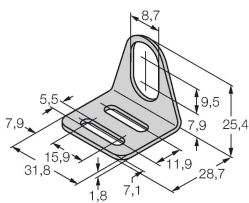

**BSS-08** 6901322

Mounting clamp for smooth and threaded barrel sensors; material: Polypropylene

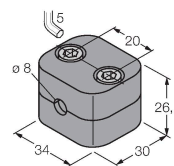

**MBS80** 69479

Mounting clamp for smooth barrel sensors; mounting block material: Anodized aluminum

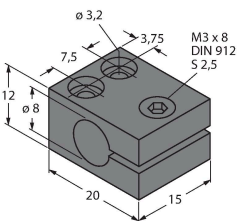

## Accessories

| Dimension drawing | Type | ID |  |
|-------------------|------|----|--|
|-------------------|------|----|--|

IM1-22EX-T

7541232

Isolating switching amplifier, 2-channel; 2 transistor outputs; input NAMUR signal; selectable ON/OFF mode for wire-break and short-circuit monitoring; switchable between NO / NC mode; removable terminal blocks; width 18 mm; universal voltage supply unit

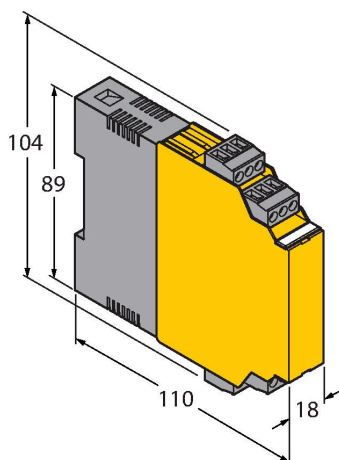

| Dimension drawing | Type                     | ID      |  |
|-------------------|--------------------------|---------|--|
|                   | IMX12-DI01-2S-2T-0/24VDC | 7580020 | Isolating switching amplifier, 2-channel; SIL2 acc. to IEC 61508; Ex-proof version; 2 transistor outputs; input Namur signal; ON/OFF switchable monitoring of wire-break and short-circuit; toggle between NO/NC mode; signal doubling; removable screw terminals; 12.5 mm wide; 24 VDC power supply |

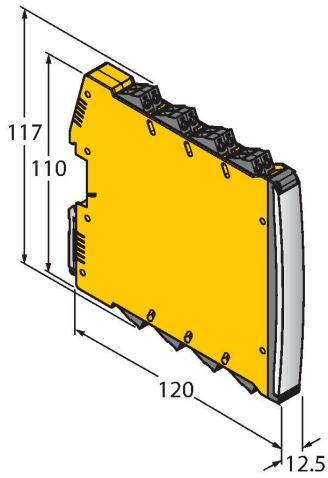

## Instructions for use

|  |  |
|--|--|
| Intended use   | This device fulfills Directive 2014/34/EC and is suited for use in explosion-hazardous areas according to EN 60079-0:2018 and EN 60079-11:2012. It is also suitable for use in safety-related systems, including SIL2 (IEC 61508) and PL c (ISO 13849-1) with HFT0 and SIL3 (IEC 61508) and PL e (ISO 13849-1) with redundant configuration HFT1. In order to ensure that the device is operated as intended, the national regulations and directives must be observed.  |
| For use in explosion hazardous areas conform to classification | II 1 G and II 1 D (Group II, Category 1 G, electrical equipment for gaseous atmospheres and category 1 D, electrical equipment for dust atmospheres).  |
| Marking (see device or technical data sheet)                   | Ex II 1 G and Ex ia IIC T6 Ga and Ex II 1 D Ex ia IIIC T135 °C Da acc. to EN 60079-0, -11  |
| Local admissible ambient temperature                           | -25...+70 °C   |
| Installation/Commissioning                                     | These devices may only be installed, connected and operated by trained and qualified staff. Qualified staff must have knowledge of protection classes, directives and regulations concerning electrical equipment designed for use in explosion hazardous areas. Please verify that the classification and the marking on the device comply with the actual application conditions.<br><br>This device is only suited for connection to approved Exi circuits according to EN 60079-0 and EN 60079-11. Please observe the maximum admissible electrical values. After connection to other circuits the sensor may no longer be used in Exi installations. When interconnected to (associated) electrical equipment, it is required to perform the "Proof of intrinsic safety" (EN60079-14). Attention! When used in safety systems, all content of the security manual must be observed. |
| Installation and mounting instructions                         | Avoid static charging of cables and plastic devices. Please only clean the device with a damp cloth. Do not install the device in a dust flow and avoid build-up of dust deposits on the device. If the devices and the cable could be subject to mechanical damage, they must be protected accordingly. They must also be shielded against strong electro-magnetic fields. The pin configuration and the electrical specifications can be taken from the device marking or the technical data sheet.  |
| Service/Maintenance  | Repairs are not possible. The approval expires if the device is repaired or modified by a person other than the manufacturer. The most important data from the approval are listed.  |