

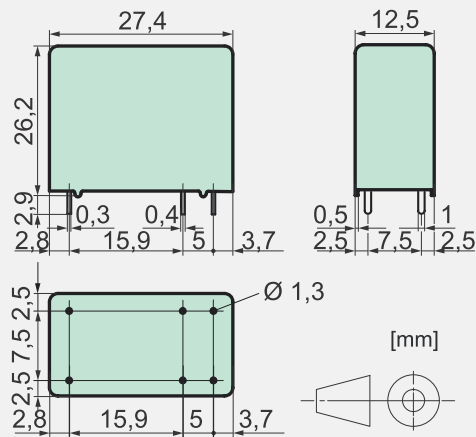

Relay Key Data

- PCB Relay with forcibly guided Contacts
- Protective separation between coil and contacts (leakage and creepage distances >14 mm); protective separation diagonally between left and right contact side (leakage and creepage distances >5,5 mm)
- EN50205 type A
- Contact mounting: SIM112 1 NO / 1 NC
- Small external dimensions
- Nominal coil power 0,5 W
- Holding coil power 0,15 W

Dimensions



Contact Data

Contact material	AgSnO ₂ + 0,2 µm
Type of contact	Crest contact
Rated switching capacity	250 VAC 8 A AC1 2000 VA
Electr. life AC 1(360 cycles / h)	approx. 100000
Inrush current max.	20 A for 20 ms
Switching voltage range	5 to 250 VDC / VAC
Switching current range*	10 mA to 8 A
Switching capacity range*	60 mW to 2000 W(VA)
Contact resistance (as delivered)	≤100 mΩ / 28 V / 100 mA

*Guided values

Standard coils for direct current

(other voltages on request)

Nominal voltage VDC	Min. pick-up voltage at 20 °C	Drop-out voltage at 20 °C	Nominal current in mA	Resistance in Ohm at 20 °C
5	3,5	≥0,5	111,0	45 ± 10%
6	4,2	≥0,6	85,7	70 ± 10%
12	8,4	≥1,2	44,4	270 ± 10%
21	14,7	≥2,1	23,8	880 ± 10%
24	16,8	≥2,4	21,8	1100 ± 10%
48	33,6	≥4,8	10,9	4400 ± 13%
60	42,0	≥6,0	8,7	6850 ± 15%
110	77,0	≥11,0	5,5	20000 ± 15%

Circuit Diagram (view on relay upper side)

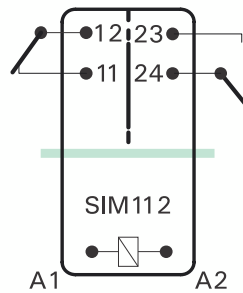

Insulation Data

- Double or reinforced insulation	at 250 VAC
- Air and creepage distance	>5,5 mm
- Test voltage	4000 V / 50 Hz / 1 min
- Double or reinforced insulation	at 250 VAC
- Air and creepage distance	>14 mm
- Test voltage	5000 V / 50 Hz / 1 min
Test voltage contact open	1500 V / 50 Hz / 1 min
Creepage resistance	CTI 250
Pollution degree	2
Overvoltage category	III
Insulation resistance at Up 500 VDC	>100 MΩ

Additional Data

Mechanical endurance	>10 x 10 ⁶ operations
Switching frequency, mechanical	15 Hz
Response time (NO closed)	typically 10 ms
Drop-out time** (NC closed)	typically 3 ms
Bounce time of NO contact	typically 6 ms
Bounce time of NC contact	typically 12 ms
Shock resistance 16 ms	NO > 10g NC > 2,5g
Vibration resistance (10-200 Hz)	NO > 10g NC > 1g
Resistance to short circuiting contacts	1000 A SCPD 10 A gG / gL (pre-fuse)
Ambient temperature	-40°C to +70°C
Thermal resistance	55 K / W
Temperature limit for coil	120°C
Weight	ca. 20 g
Mounting position	any
Type of protection	RT II
Solder bath temperature	270°C / 5 s

**without spark suppression

Tests, Regulations

Approvals



UL File E188953	Sec. 3
Insulation class IEC 60664-1	250 VAC
Fire protection requirements	UL 94 / V1

Options, Accessories

none available

Product Key

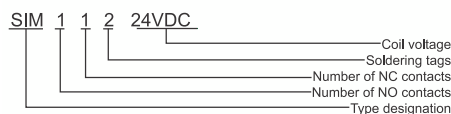

Contact Lifetime NO-Contact

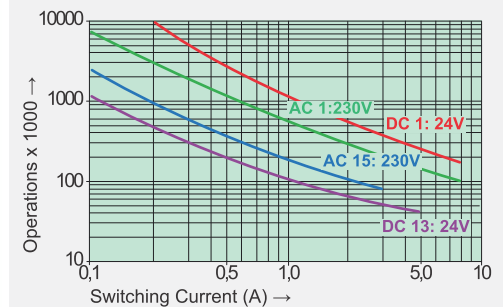

Maximal switching characteristics (DIN EN60947-5-1, Tab. C2)

AC 1:	250 V / 8 A
AC 15:	230 V / 3 A
DC 1:	24 / 8 A
DC 13:	24 V / 6 A / 0,1 Hz
UL 508:	C150 / R300

Load Limit Curve with Direct Current

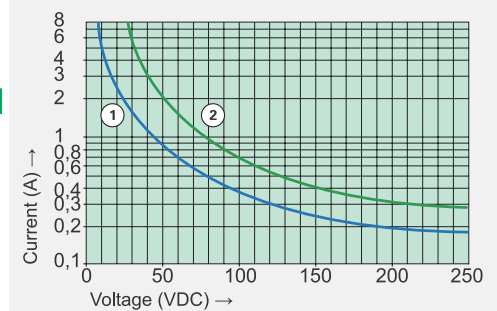

- 1) Inductive load L/R 40 ms
- 2) Resistive load

Excitation Voltage Range

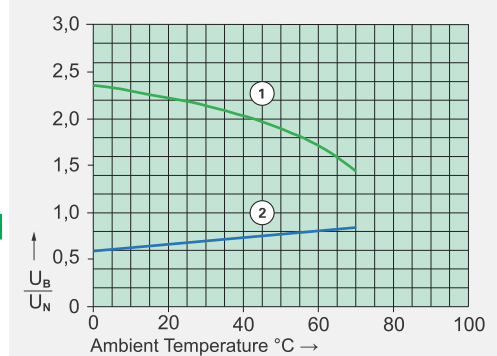

- 1) Max. excitation voltage with contact load: ≤6 A
- 2) Min. excitation voltage (guaranteed values) without previous operation

No heat accumulation due to intrinsic heating of other components. Continuous duty 100%.