

IM1-121EX-R

Isolating switching amplifier – 1-channel

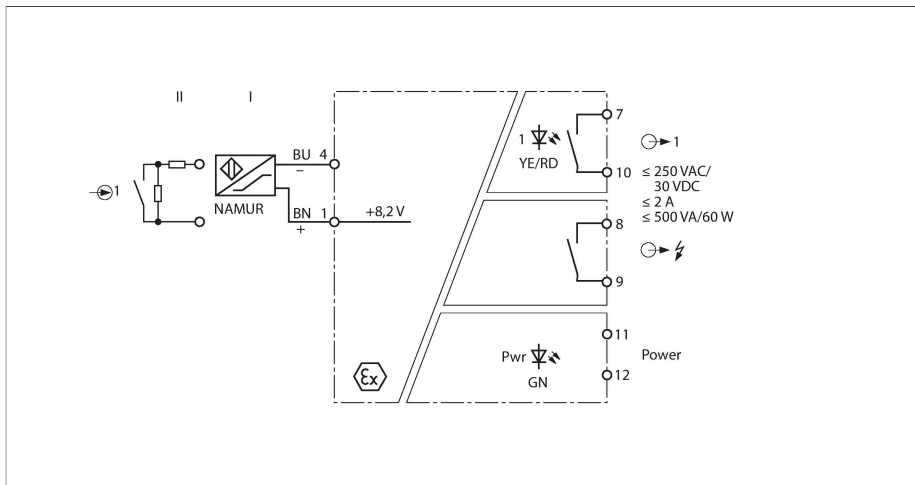

The 1-channel IM1-12EX-R isolating switching amplifier is equipped with an intrinsically safe input circuit.

Sensors according to EN 60947-5-6 (NAMUR) or potential-free contact transmitters can be connected to the device.

The output circuit features 2 relays each with an NO contact, one of which works as an alarm output.

You can toggle between working or closed current, i.e. NO or NC mode, via three switches at the front. The switching state of channel 1 is thereby transmitted to output 1.

When using mechanical contacts, wire-break and short-circuit monitoring must be switched off or the contacts must be wired to resistors (II) (see circuit diagram).

The Pwr LED lights green to indicate operational readiness. The 2-color LED 1 lights yellow to indicate the switching status of the output. In the event of an input circuit error, the 2-color LED turns red, with the input circuit monitoring switched on. Thereupon the output and the alarm relay drop out.

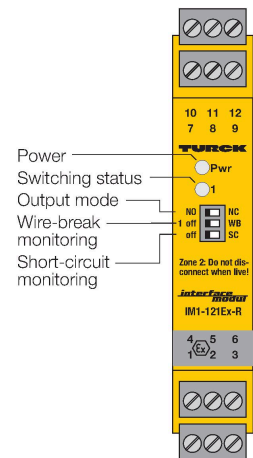

Features

- 2 relay outputs (NO)
- Output mode adjustable (NO/NC mode)
- Common alarm output
- Input circuits monitored for wire-break/short-circuit (ON/OFF switchable)
- SIL 2
- Complete galvanic isolation
- Input reverse-polarity protected
- ATEX, IECEx, cUL, cFM, CSA, TR CU, NEPSI, KOSHA, TIIS, CCOE, INMETRO
- Installation in zone 2

Dimensions

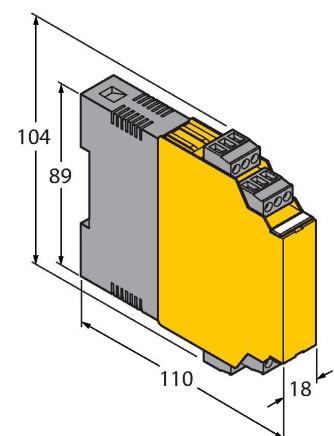

Technical data

Type	IM1-121EX-R
ID	7541229
Nominal voltage	Universal voltage supply unit
Operating voltage	20...250 VAC
Frequency	40...70 Hz
Operating voltage	20...125 VDC
Power consumption	≤ 3 W
Power dissipation, typical	≤ 0.98 W
NAMUR input	
NAMUR	EN 60947-5-6
Input circuit monitoring	on/off switchable
No-load voltage	8.2 VDC
Short-circuit current	8.2 mA
Input resistance	1 kΩ
Cable resistance	≤ 50 Ω
Switch-on threshold	1.75 mA
Switch-off threshold	1.55 mA
Wire breakage threshold	≤ 0.06 mA
Short-circuit threshold	≥ 6.4 mA
Output circuits (digital)	2 x relays (NO)
Output switching voltage relay	≤ 30 VDC / ≤ 250 VAC
Switching current per output	≤ 2 A
Switching capacity per output	≤ 500 VA/60 W
Switching frequency	≤ 10 Hz
Galvanic isolation	
Test voltage	2.5 kV RMS
Important note	For Ex-applications the values specified in the corresponding Ex certificates (ATEX, IECEx, UL, etc.) apply.
Ex approval acc. to conformity certificate	TÜV 04 ATEX 2553
Application area	II (1) G, II (1) D
Ignition protection category	[Ex ia Ga] IIC; [Ex ia Da] IIIC
Ex approval acc. to conformity certificate	TÜV 06 ATEX 552968 X
Application area	II 3 G
Ignition protection type	Ex nA nC [ic Gc] IIC/IIB T4 Gc
Characteristic	linear
Important note	If the device is used in applications to achieve functional safety according to IEC 61508, the safety manual must be used. Information in the data sheet are not valid for functional safety.
Approval	SIL 2 acc. to EXIDA FMEDA
Use in SIL safety circuits	SIL 2

Output relay – Load curve

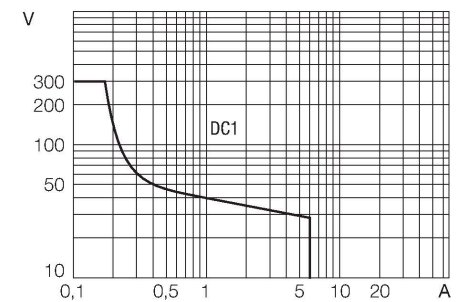

Output relay – Electrical lifetime

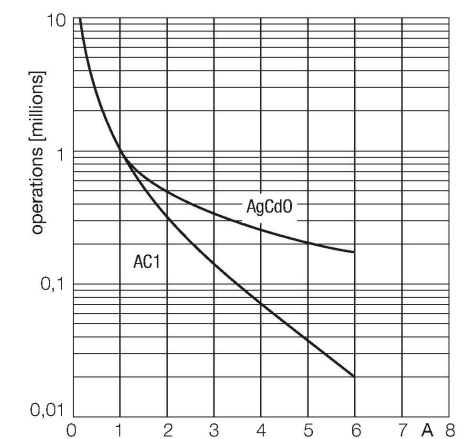

Technical data

Indication	
Power on display	Green
Switching state	Yellow
Error indication	red
Mechanical data	
Protection class	IP20
Flammability class acc. to UL 94	V-0
Ambient temperature (min.)	-25
Ambient temperature (max.)	70
	-25 ... +60 °C für UL, FM, TIIS
Storage temperature	-40...+80 °C
Dimensions	104 x 18 x 110 mm
Weight	171 g
Mounting instructions	DIN rail (NS35) or panel
Housing material	Polycarbonate/ABS
Electrical connection	4 x 3-pin removable terminal blocks, reverse polarity protected, screw terminal
Terminal cross-section	1 x 2.5 mm ² / 2 x 1.5 mm ²
Tightening torque	0.5 Nm

Accessories

WM1 WIDERSTANDSMODUL

0912101

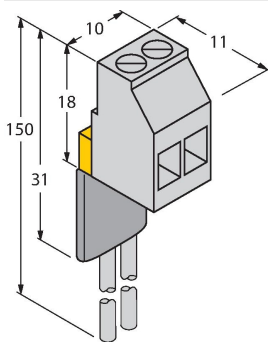

The resistor module WM1 meets the requirements for line monitoring between a mechanical contact and a TURCK signal processor. The input circuit of the signal processor is designed for sensors acc. to EN60947-5-6 (NAMUR) and equipped with a wire-break and short-circuit monitoring function.

IM-CC-3X2BU/2BK

6900475

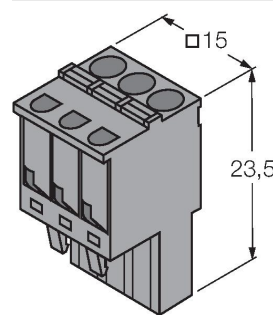

Cage clamp terminals for IM modules (Ex-devices with 18 mm overall width); includes: 2 pcs. 3-pin blue terminals and 2 pcs. 3-pin black terminals.