

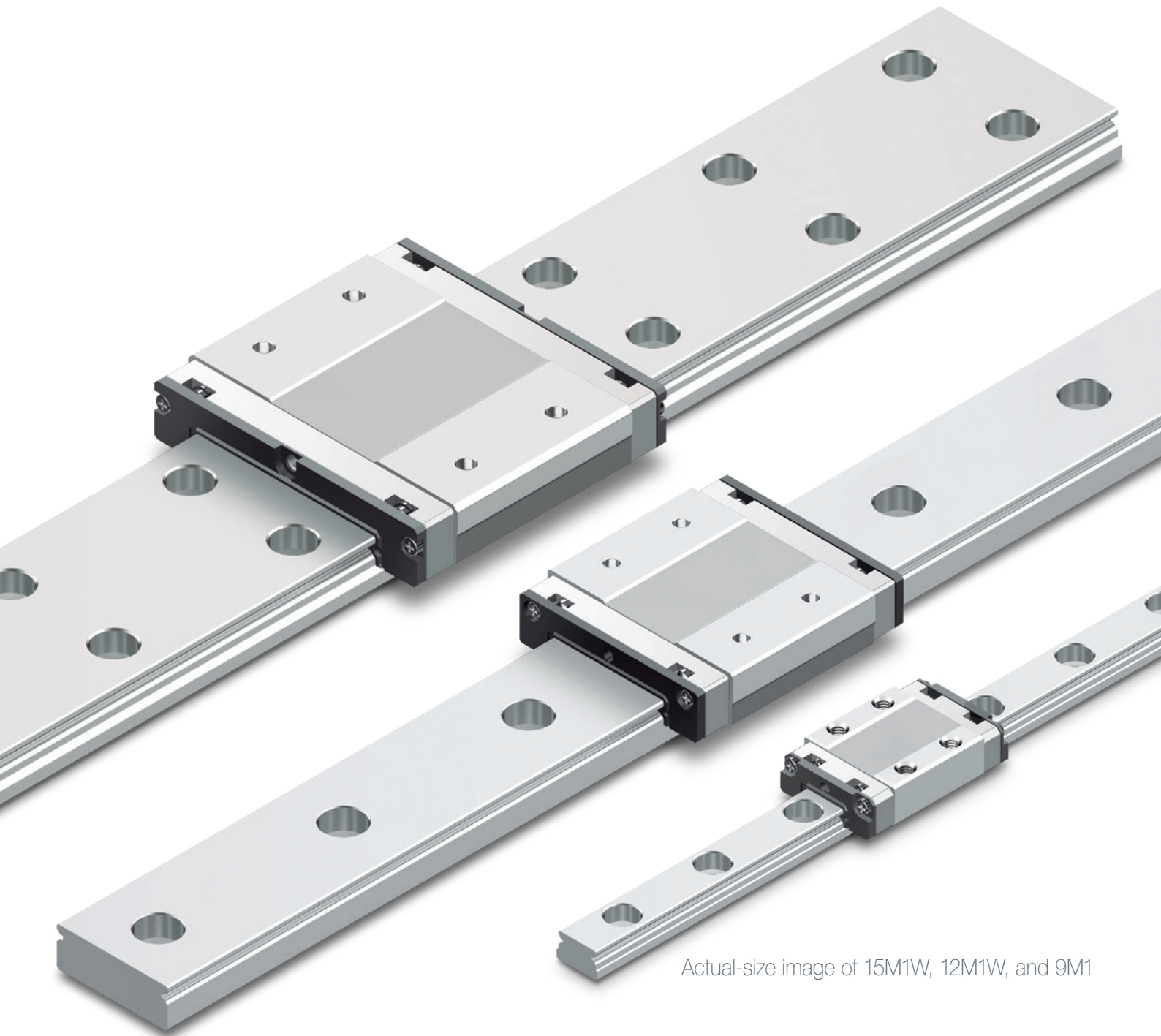

NEW

High-Temperature LM Guide

RSX-M1



Actual-size image of 15M1W, 12M1W, and 9M1

Optimized circulation for smooth movement
Miniature LM Guide for use in temperatures as high as 150°C

RSX-M1 High-Temperature LM Guide

Structure and Features

The Model RSX-M1 uses two raceways and has more compact outer dimensions than models with four raceways. Despite being compact, its ball contact structure is capable of receiving loads in all directions, and can be used individually in locations with space limitations or where moments are applied. The Model RSX-M1 utilizes unique material, lubrication, and heat treatment technology to raise its maximum service temperature to 150°C.

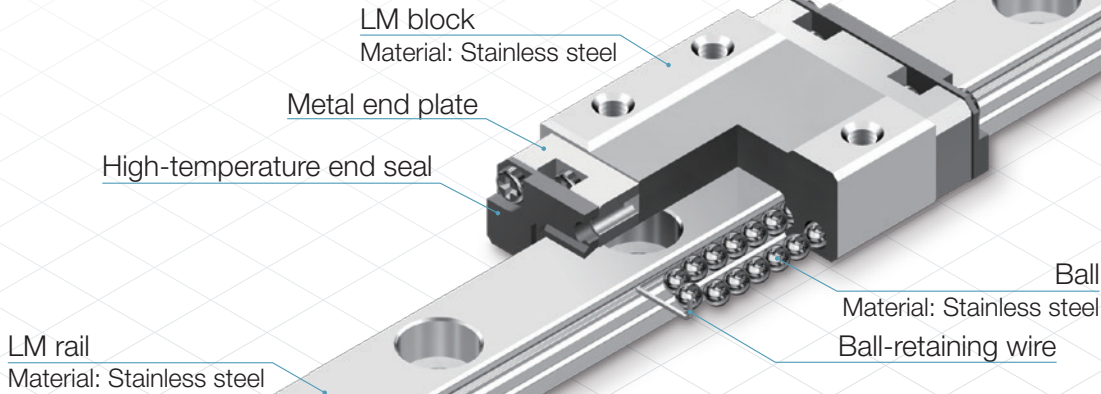

Maximum Service Temperature: 150°C

The LM block and LM rail incorporate specialized materials and heat treatment technology to withstand a maximum service temperature of 150°C.

High-Temperature Grease

This model uses high-temperature grease that shows little grease-based fluctuation in rolling resistance even if the temperature changes from normal to high levels.

Lineup

	Block type	RSX9M1	RSX12M1	RSX15M1
Standard type	Standard block	○	○	○
	Long block (N)	○	○	○
Wide type (W)	Standard block	○	○	○
	Long block (N)	○	○	○

RSX-M1

This model is the standard type.

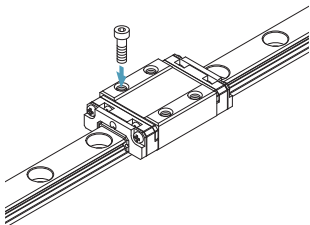

RSX-M1N

This type has a longer overall LM block length (L) and a higher load rating than the Model RSX-M1.

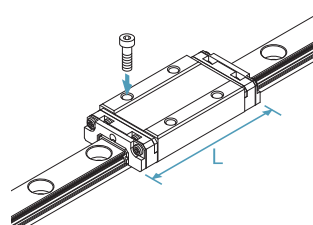

RSX-M1W

This type has a longer overall LM block length (L), a greater width, and a larger rated load and permissible moment than RSX-M1.

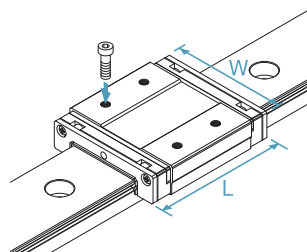

RSX-M1WN

This type has a longer overall LM block length (L) and a higher load rating than the Model RSX-M1W.

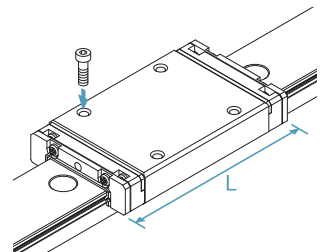

Specification Table

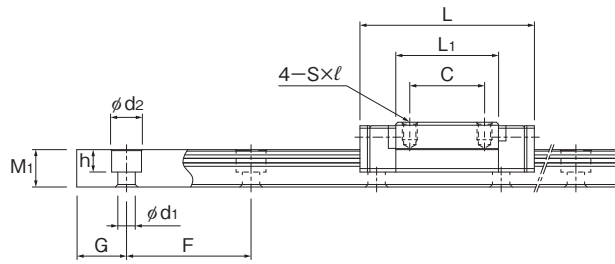
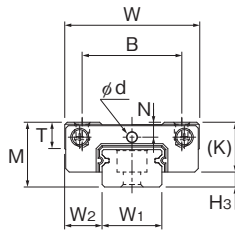

RSX9M1, 12M1

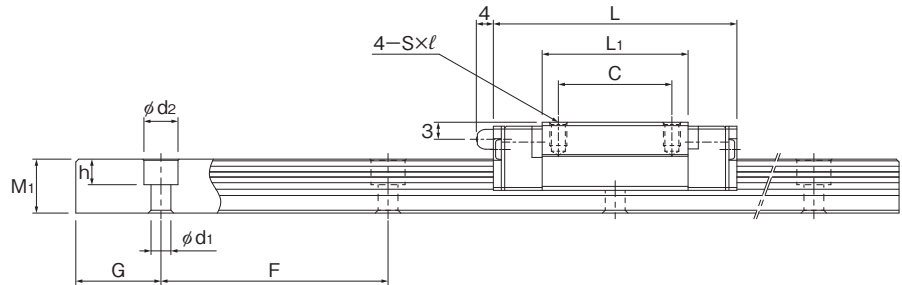
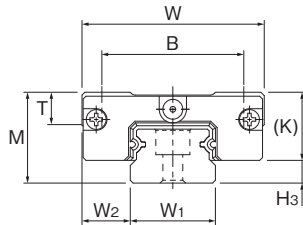

RSX15M1

Unit: mm

Model No.	Outer dimensions			LM block dimensions								H ₃	LM rail dimensions							Basic load rating		Mass	
	Height M	Width W	Length L	B	C	S × ℓ	L ₁	T	K	N	Greasing hole d		Width W ₁ 0 -0.02	W ₂	W ₃	Height M ₁	G	Pitch F	d ₁ × d ₂ × h	Max. length	C (kN)	C ₀ (kN)	LM block (kg)
RSX 9M1	10	20	30.8	15	10	M3×2.8	19.8	-	7.8	2.4	1.6	2.2	9	5.5	5.5	7.5	20	3.5×6×3.3	1240	2.22	3.06	0.018	0.32
RSX 9M1N	10	20	40.8	15	16	M3×2.8	29.8	-	7.8	2.4	1.6	2.2	9	5.5	5.5	7.5	20	3.5×6×3.3	1240	2.94	4.59	0.024	0.32
RSX 12M1	13	27	35	20	15	M3×3.5	20.6	5.3	10	3	2	3	12	7.5	7.5	10	25	3.5×6×4.5	2000	3.36	4.21	0.037	0.65
RSX 12M1N	13	27	47.7	20	20	M3×3.5	33.3	5.3	10	3	2	3	12	7.5	7.5	10	25	3.5×6×4.5	2000	4.72	6.83	0.047	0.65
RSX 15M1	16	32	42.9	25	20	M3×4	25.7	5.8	12	3	-	4	15	8.5	9.5	15	40	3.5×6×4.5	2000	5.59	6.78	0.069	0.96
RSX 15M1N	16	32	60.7	25	25	M3×4	43.5	5.8	12	3	-	4	15	8.5	9.5	15	40	3.5×6×4.5	2000	8.27	11.8	0.089	0.96

Note) Max. length indicates the standard maximum length of the LM rail. Note) RSX15 has a PB107 grease nipple installed. RSX9 and 12 are equipped with greasing holes.

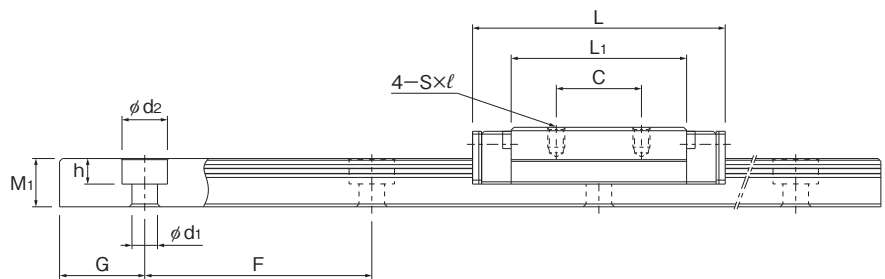
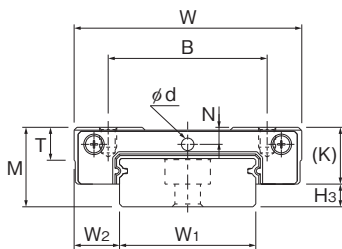

RSX9M1W, 12M1W

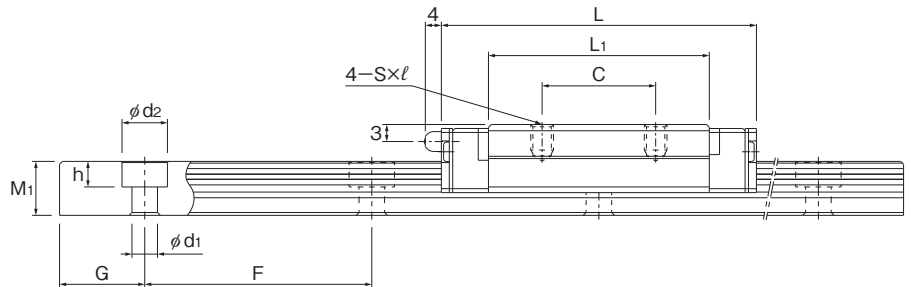
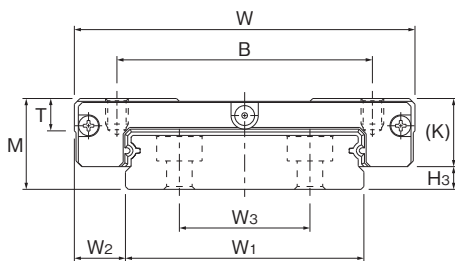

RSX15M1W

Unit: mm

Model No.	Outer dimensions			LM block dimensions								H ₃	LM rail dimensions							Basic load rating		Mass		
	Height M	Width W	Length L	B	C	S × ℓ	L ₁	T	K	N	Greasing hole d		Width W ₁ 0 -0.02	W ₂	W ₃	Height M ₁	G	Pitch F	d ₁ × d ₂ × h	Max. length	C (kN)	C ₀ (kN)	LM block (kg)	LM rail (kg/m)
RSX 9M1W	12	30	39	21	12	M3×2.8	27	-	8.3	2.3	1.6	3.7	18	6	-	7.5	10	30	3.5×6×4.5	1430	2.8	4.28	0.035	1.01
RSX 9M1WN	12	30	50.7	23	24	M3×2.8	38.7	-	8.3	2.3	1.6	3.7	18	6	-	7.5	10	30	3.5×6×4.5	1430	3.48	5.81	0.048	1.01
RSX 12M1W	14	40	44.5	28	15	M3×3.5	30.9	4.5	10	3	2	4	24	8	-	8.5	15	40	4.5×8×4.5	2000	4.46	6.31	0.075	1.52
RSX 12M1WN	14	40	59.5	28	28	M3×3.5	45.9	4.5	10	3	2	4	24	8	-	8.5	15	40	4.5×8×4.5	2000	5.93	9.46	0.091	1.52
RSX 15M1W	16	60	55.5	45	20	M4×4.5	38.9	5.6	12	3	-	4	42	9	23	9.5	15	40	4.5×8×4.5	2000	7.43	10.1	0.17	2.87
RSX 15M1WN	16	60	74.5	45	35	M4×4.5	57.9	5.6	12	3	-	4	42	9	23	9.5	15	40	4.5×8×4.5	2000	9.87	15.2	0.195	2.87

Note) Max. length indicates the standard maximum length of the LM rail. Note) RSX15 has a PB107 grease nipple installed. RSX9 and 12 are equipped with greasing holes.

Accuracy Standards

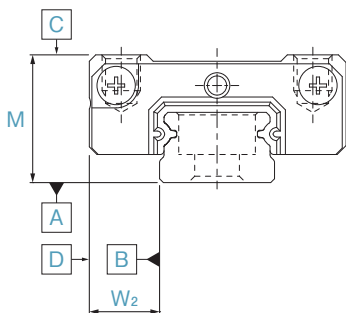

Accuracy Standards

Unit: mm

Model No.	Accuracy standards Item	Normal grade	High accuracy grade	Precision grade
		No symbol	H	P
RSX9M1/9M1W	Dimensional tolerance in height (M)	±0.04	±0.02	±0.01
	Difference in height (M)	0.03	0.015	0.007
	Dimensional tolerance in width (W ₁)	±0.04	±0.025	±0.015
RSX12M1/12M1W	Difference in width (W ₂)	0.03	0.02	0.01
RSX15M1/15M1W	Running parallelism of surface C against surface A	See the table on the right		
	Running parallelism of surface D against surface B	See the table on the right		

Running Parallelism

Unit: μm

LM rail length (mm)		Running parallelism values		
Above	Or less	Normal grade	High accuracy grade	Precision grade
—	40	8	4	1
40	70	10	4	1
70	100	11	4	2
100	130	12	5	2
130	160	13	6	2
160	190	14	7	2
190	220	15	7	3
220	250	16	8	3
250	280	17	8	3
280	310	17	9	3
310	340	18	9	3
340	370	18	10	3
370	400	19	10	3
400	430	20	11	4
430	460	20	12	4
460	520	21	12	4
520	550	22	12	4
550	640	22	13	4
640	670	23	13	4
670	700	23	13	5
700	820	23	14	5
820	850	24	14	5
850	970	24	15	5
970	1030	25	16	5
1030	1150	25	16	6
1150	1330	26	17	6
1330	1420	27	18	6
1420	1510	27	18	7
1510	1830	28	19	7
1830	2000	28	19	8

Radial Clearance Specifications

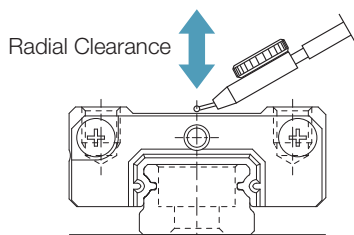

Radial Clearance Specifications

Unit: μm

Model No.	Normal (No symbol)	Light preload (C1)
RSX9M1/9M1W	-2 to +2	-4 to 0
RSX12M1/12M1W	-3 to +3	-6 to 0
RSX15M1/15M1W	-5 to +5	-10 to 0

Model Number Coding

Select an option

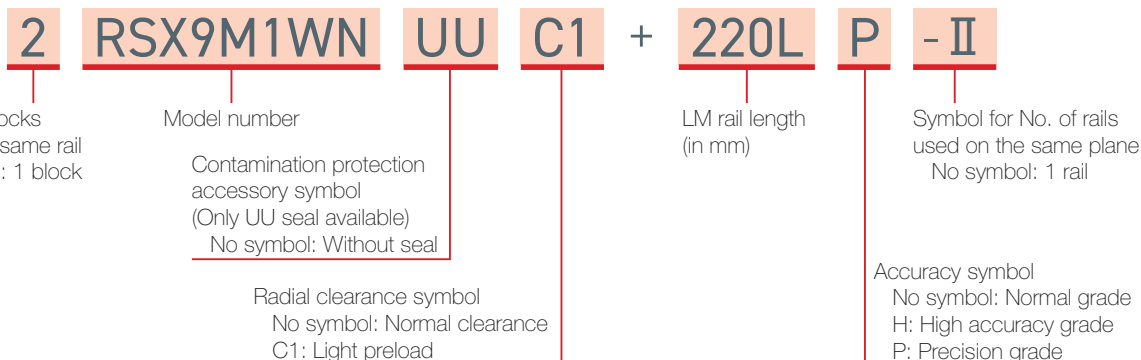

THK CO., LTD.

Headquarters 2-12-10 Shibaura, Minato-ku, Tokyo 108-8506 Japan

International Sales Department Phone: +81-3-5730-3860

www.thk.com

North America

THK America, Inc.

- HeadquartersPhone: +1-847-310-1111
- Chicago OfficePhone: +1-847-310-1111
- North East OfficePhone: +1-631-244-1565
- Atlanta OfficePhone: +1-770-840-7990
- Los Angeles OfficePhone: +1-949-955-3145
- San Francisco OfficePhone: +1-925-455-8948
- Detroit OfficePhone: +1-248-858-9330
- Toronto OfficePhone: +1-905-820-7800

South America

THK BRAZIL INDUSTRIA E COMERCIO LTDA.

Phone: +55-11-3767-0100

Europe

THK GmbH

- European HeadquartersPhone: +49-2102-7425-555
- Düsseldorf OfficePhone: +49-2102-7425-0
- Stuttgart OfficePhone: +49-7141-4988-500
- U.K. OfficePhone: +44-1384-471550
- Italy OfficePhone: +39-02-9901-1801

- Sweden OfficePhone: +46-8-445-7630
- Austria OfficePhone: +43-7229-51400
- Spain OfficePhone: +34-93-652-5740
- Turkey OfficePhone: +90-216-362-4050
- Prague OfficePhone: +420-2-41025-100
- Moscow OfficePhone: +7-495-649-80-47
- THK Europe B.V.
- Eindhoven OfficePhone: +31-40-290-9500
- THK France S.A.S.
- Paris OfficePhone: +33-1-7425-3800

China

THK (CHINA) CO., LTD.

- HeadquartersPhone: +86-411-8733-7111
- Shanghai BranchPhone: +86-21-6219-3000
- Beijing BranchPhone: +86-10-8441-7277
- Chengdu BranchPhone: +86-28-8526-8025
- Guangzhou BranchPhone: +86-20-8523-8418
- Shenzhen BranchPhone: +86-755-2642-9587
- Xian BranchPhone: +86-29-8834-1712
- THK (SHANGHAI) CO., LTD.Phone: +86-21-6275-5280

Taiwan

THK TAIWAN CO., LTD.

- Taipei HeadquartersPhone: +886-2-2888-3818
- Taichung OfficePhone: +886-4-2359-1505
- Tainan OfficePhone: +886-6-289-7668

South Korea

- Seoul Representative OfficePhone: +82-2-3468-4351

Singapore

THK LM System Pte. Ltd.Phone: +65-6884-5500

Thailand

THK RHYTHM (THAILAND) CO., LTD. LM System Division

- Bangkok BranchPhone: +66-2751-3001

India

THK India Pvt. Ltd.

- Headquarters & Bengaluru BranchPhone: +91-80-2340-9934
- Pune BranchPhone: +91-72-7600-2071
- Chennai BranchPhone: +91-44-4042-3132
- Ahmedabad BranchPhone: +91-79-6134-4925
- Delhi BranchPhone: +91-12-4676-8695