

Compact positioner in digital technology for mounting on pneumatic valves

- Direct „top-mounted“ attachment to the valve drive. This means that no parts of the stroke return are accessible from the outside.
- Large stroke range 3 - 28 mm, optionally up to 50 mm.
- Reverse hysteresis of up to 0.2% possible, standard 0.4%
- Configuration adjustment through self-adaption
- Configuration and diagnostic functions via free „DeviceConfig“ software
- Low vibration sensitivity
- Protection class IP 65
- On request also available in version for Ex zone 22
- Available with integrated process controller
- Also for rotary actuators (single or double-acting)
- Low air consumption in the regulated state



ATEX-Versions:



ATEX



II 2G Ex ia IIC T4 Gb for Type 8049-ExPro-1

II 1G Ex ia IIC T4 Ga for Type 8049-ExPro-0

Technical Information, standard versions

Version	8049-4**	8049-2	8049-ExPro
nominal stroke	3 - 28 mm (optional up to 50mm)		
voltage of the working resistance	2,5 V (125Ω@20mA)	6,5 V (325Ω@20mA)	8V (400Ω@20mA)
auxiliary energy, pneumatic	max. 6 bar	max. 6 bar	max. 6 bar
air delivery* linear drive	40 NI/min	24 NI/min	24 NI/min
air consumption	< 0,06 NI/min	< 0,4 NI/min	< 0,4 NI/min
Leakage	< 0,01 NI/min		
ambient temperature	-20 up to +75°C	-10 up to +75°C	-10 up to +75°C
control signal	0/4 - 20 mA opt. 0,2 - 10 V	4 - 20 mA	4 - 20 mA
auxiliary energy, electric	24 VDC max. 10 W	none	none
adjustment of stroke and zero point	self-learning		
configuration	with PC-Software		
air quality according ISO 8573-1:			
max. particle size and density:	Class 5	Class 3	Class 3
oil content	Class 4	Class 2	Class 2
pressure dew point	Class 3	Class 3	Class 3
	min. 20K (36°F) under ambient temperature		
Actuation gas	compressed air or non flammable gases (nitrogen, CO ₂ ,...)		
mounting to control valve	standardized mounting kits (also with optical position indicator)		
pressure supply port	G 1/8"		
Max.connection section	1,5mm ²		
protection class acc. DIN 40050	IP 65		

* at 5 bar pilot pressure

** from version 4P6

Technical Information, ex-versions

Version	8049-ExPro-1	8049-ExPro-0
General explosion-relevant information		
Applied standards	IEC 60079-0:2011, Ed. 6 IEC 60079-11:2011, Ed. 6	
Type examination certificate (ATEX)	BVS 17 ATEX E088	
Type examination certificate (IEC)	IECEX BVS 17.0080	
ATEX label	II 2G Ex ia IIC T4 Gb	II 1G Ex ia IIC T4 Ga
IEC label	Ex ia IIC T4 Gb	Ex ia IIC T4 Ga
Temperature ranges	Tamb = -10 ... +75°C	
Explosion-relevant information for control signal input (Terminals 1 and 2)		
Max. input voltage	Ui = DC 30V	Ui = DC 30V
Max. input current	li = 120 mA	li = 120 mA
Max. input power	Pi = 1000 mW	Pi = 1000 mW
Max. interior capacity	Ci = negligible	Ci = negligible
Max. interior inductivity	Li = negligible	Li = negligible
Explosion-relevant information for alarm output (NAMUR EN 60947-5-6) (Terminals 3 und 4)		
Max. input voltage	Ui = DC 16V	Ui = DC 16V
Max. input current	li = 25 mA	li = 25 mA
Max. input power	Pi = 64 mW	Pi = 64 mW
Max. interior capacity	Ci = 11 nF	Ci = 11 nF
Max. interior inductivity	Li = negligible	Li = negligible
Explosion-relevant information for binary input (Terminals 5 and 6)		
Max. output voltage	Uo = DC 5.4V	Uo = DC 5.74V
Max. output current	Io = 1 mA	Io = 1 mA
Max. output power	Po = 2 mW	Po = 2 mW
Max. external capacity	Co = 65 µF	Co = 65 µF
Max. external inductivity	Lo = 50 mH	Lo = 50 mH
Explosion-relevant information for PC-COM		
Nominal output voltage	2,8V	2,8V
Max. output voltage	Um = 6.1 V	Um = 6.1 V
Restriction	The interface may only be used for configuration provided that there is no explosive atmosphere.	
Explosion-relevant information for the external path sensor (version with Plug 4)		
Max. output voltage	Uo = 5.4 V	Uo = 5.4 V
Max. output current	Io = 66 mA	Io = 66 mA
Max. output power	Po = 89 mW	Po = 89 mW
Max. external capacity	Co = 59,5 µF	Co = 59,5 µF
Max. external inductivity	Lo = 8 mH	Lo = 8 mH

Combination possibilities

	8049-4 (4-wire) version V6	8049-2 (2-wire) version V7	8049-ExPro (ex-version) Version V3	8049-IPC with integrated process controller
standard body	x	x	x	x
ground plate in stainless steel	x	x	x	x
positioner completely in stainless steel	x	x	x	
positioner for part turn actuator single acting	x	x	x	x
positioner for part turn actuator double acting	x			x
positioner for 50 mm stroke	x	x	x	
feed back module RM-4		x	x	
feed back module RM-5	x			
gauge block	x	x	x	x

Accessories

Analogue feedback modules

- Feedback on current valve position
- Feedback signal does not require calibration
- Easy to retrofit

Analogue feedback module RM-4 for 8049-2 and 8049-ExPro

- Feedback for 2 wire design and ExPro
- 2 limit signal transmitters according NAMUR (EN60947-5-6)
- Limit signal transmitters freely adjustable (0-100%) with software „DeviceConfig“

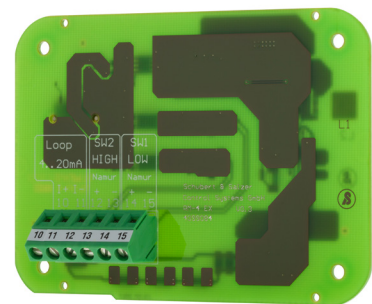

Technical Information

Output signal	4 - 20 mA
Internal load	< 8V (400 Ω)
Temperature range	-20 . . . +75°C
Accuracy Feedback	± 1,5%
Limit signal transmitters	2 pieces (NAMUR)
Switching range	adjustable 0-100%
Switching hysteresis	ca. 2,5%
Signal admissible deviation Actual value/ setpoint	±2%

Analogue feedback module RM-5 for 8049-4

- Feedback for 4 wire design from version V6
- 2 electrically isolated limit signal transmitters
- Limit signal transmitters freely adjustable (0-100%) via Software DeviceConfig
- Binary input 24V

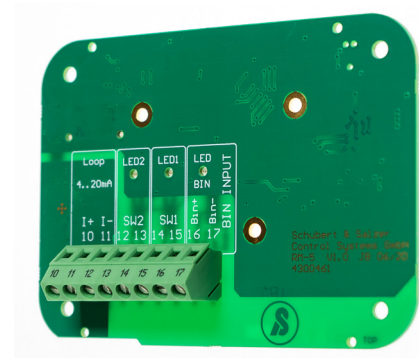

Technical Information

Supply voltage	24V DC (±10%)
Output signal	4 - 20 mA
Max. adm. working resistance	500 Ohm
Temperature range	-20 . . . +75°C
Limit signal transmitters	2 pieces
Switching range	adjustable 0-100%
Switching capacity of the limit sign.trans.	24V AC/DC , 70mA
Switching hysteresis	ca. 2,5%
Signal admissible deviation Actual value/ setpoint	±2%

Gauge block

- Gauge block between positioner and connection block
- Reading range of 0-6 bar
- Pressure reading in bar and PSI
- Easy to retrofit



optical position indication for quarter-turn actuators



Materials

	standard version	version „ground plate in stainless steel“	version „completely stainless steel“
positioner housing	Vestamid (electroconductive)	Vestamid (electroconductive)	stainless steel
ground plate	Aluminium, KTL-coated	stainless steel	stainless steel

Housing Versions

Standard version

Ground plate in stainless steel

Completely stainless steel



Ordering number system

										quote only if required	
8049/		-								S	-
Basic design											
dig. positioner 8049-4 (version 6)	4P6										
dig. positioner 8049-2	2P7										
dig. positioner 8049-ExPro-1	EP3										
dig. positioner 8049-ExPro-0	OP3										
For actuator											
single acting		1									
double acting		2									
Air delivery											
standard										S	
high „standard“ for Quarter-turn actuators										H	
Body											
aluminium / plastic											0
stainless steel ground plate											1
body in stainless steel											2
Electro-pneumatic connection											
cable bushing 2 x M16x1,5											0
NPT-thread 1/2“											1
plug connection M12x1, 5-pin											2
Pneumatic connection											
G 1/8“											0
NPT 1/8“											1
Position measuring											
linear potentiometer without sensing pin											0
linear potentiometer with standard sensing pin (L=99,6mm)											1
linear potentiometer with curtaed sensing pin (L=94,4 mm)											G
rotary potentiometer for semi-rotary drive											2
EMV-galvanic separating module for exterior path sensor											3
Optical indicator											
without indicator											0
indicator disc for sensing pin in PA											1
indicator disc for sensing pin in metal											2
rotation angle indicator											3
Auxiliary module											
without auxiliary module											0
intelligent feedback modul RM3 with two limiting value encoders according NAMUR											3
intelligent feedback modul RM4 with two limiting value encoders according NAMUR											4
intelligent feedback modul RM5 with two limiting value encoders											5
Accessories											
without accessories											0
manometer bloc single acting, scaling in bar and PSI											1
optical position indicator for rotating actuators											2
Further details											
special design (quote only if required)											S
positioner montage (only for the manufacturer)											M
Settings											
standard											-
settings on customer request											1
Special design											
without											-
separated version incl. exterior path sensor for lift drive											1
special design for ex zone 22 (dust)											2

Dimensions

For linear actuators

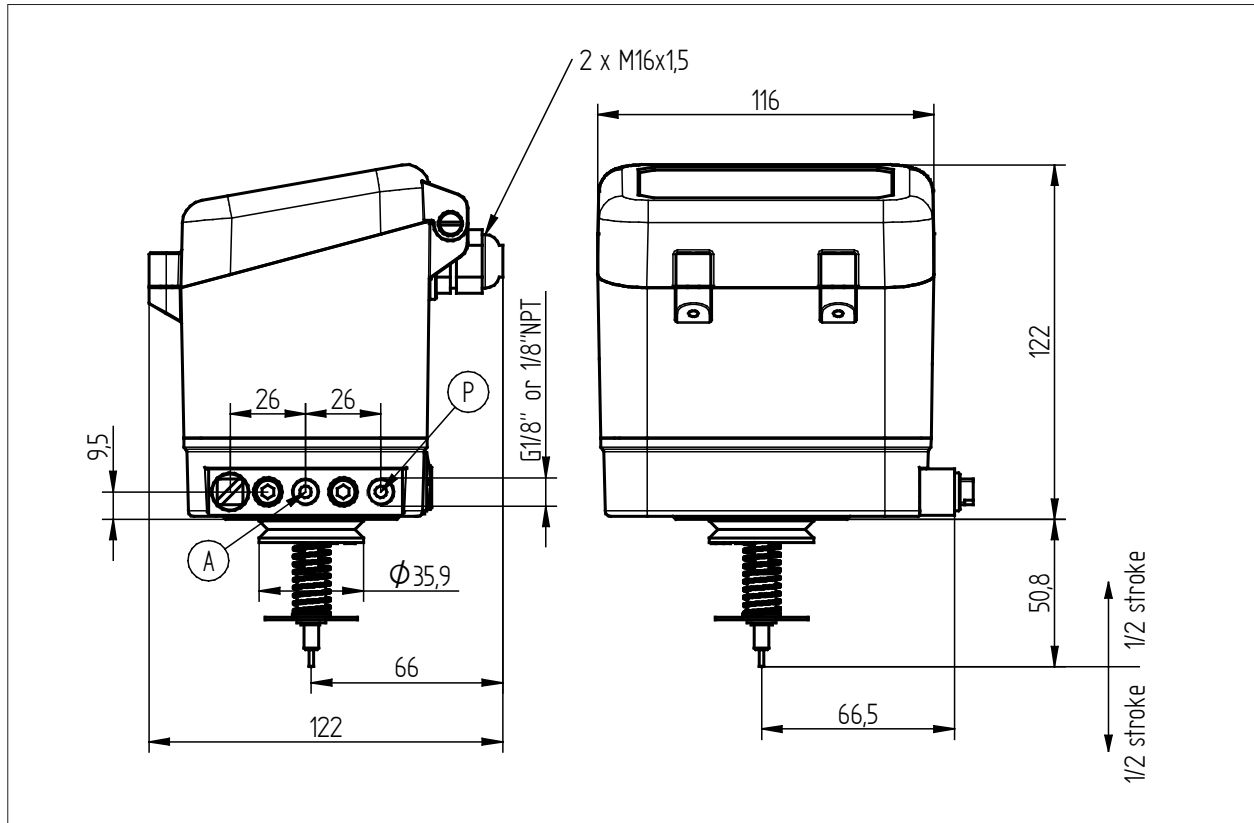

For quarter-turn actuators

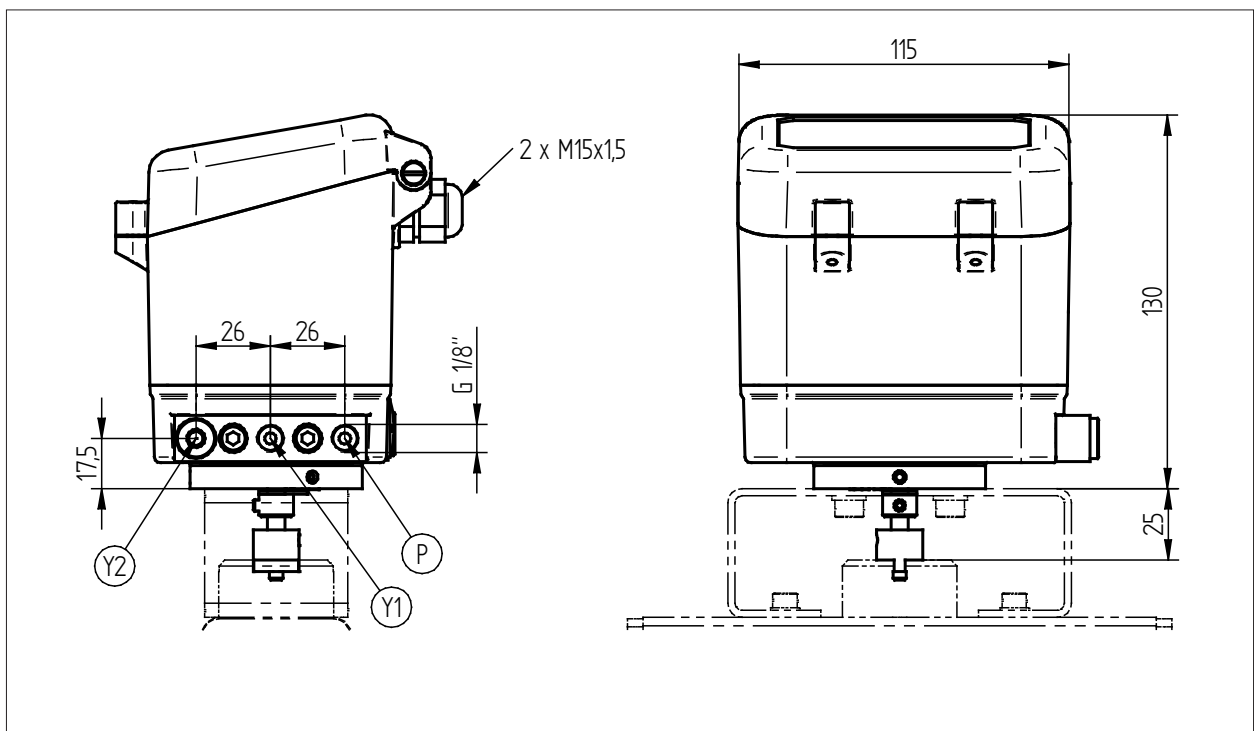

Configuration-Software „DeviceConfig“

Setup-Parameters

Adjustment of controlling parameters (input signal, stroke limitation, tight closing function, control hysteresis, valve function,...)

Live-Monitor

The operating conditions of the positioner, can be viewed with the live monitor.

Configuration-Software „DeviceConfig“

Diagnostic data

Informations of valve stroke, running time, soft- and hardware-versions, achieved temperature- and stroke levels, error messages, number of cycles, operating hours...

Base	Maintenance 1	Maintenance 2	Way classes
Results of self adaption			
Valve stroke:	8,25 mm		
Mech. middle position:	58,58%		
Top:	72,33%		
Bottom:	44,84%		
Stroke time [filling]:	0,993s		
Stroke time [draining]:	1,684s		
Production information			
Serial number:	S08000090684262		
Test date:	15.10.2021		
Version information			
Software-Version:	01.00.0		
Hardware-Version:	HW011		
Bootloader information			
Article number:	4300455		
Bootloader type	8049-4L STM32L4-HW011		
Bootloader version	2.20 20210629		
Name:			

Back

application example

Positioner 8049 top mounted on GS-Control Valve Type 8021



Positioner 8049 top mounted on Aseptic Right Angle Control Valve Type 6051 with stainless steel body



Text and pictures are not binding. We reserve the right, to alter the equipment.